

Portable Air and Power

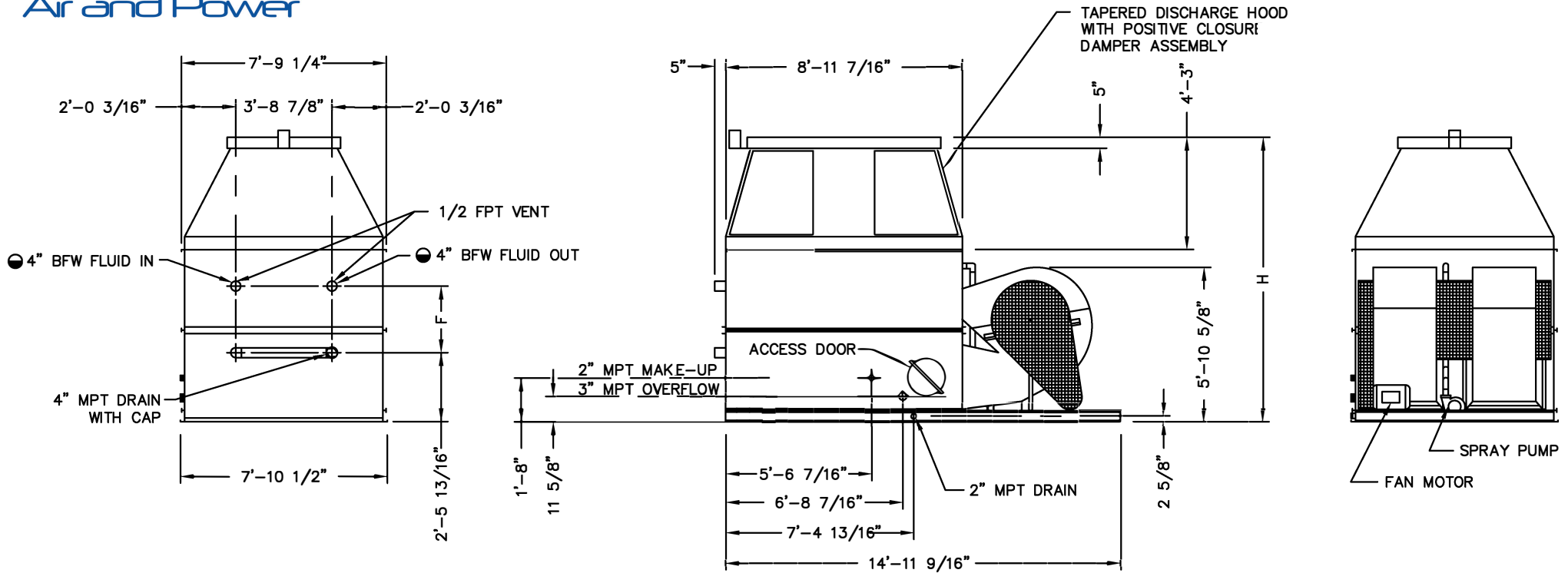

● BFW BEVELED FOR WELDING

MODEL NO.	APPROX. SHIPPING WEIGHT (LBS)	APPROX. OPERATING WEIGHT (LBS)	F	TOP OF CASING	OVERALL HEIGHT
VFL-072-22M	9665	14265	2'-9 1/4"	6'-10 1/4"	11'-1 1/4"
VFL-072-22N	9665	14265	2'-9 1/4"	6'-10 1/4"	11'-1 1/4"
VFL-072-220	9665	14265	2'-9 1/4"	6'-10 1/4"	11'-1 1/4"
VFL-072-22P	9665	14265	2'-9 1/4"	6'-10 1/4"	11'-1 1/4"
VFL-072-32N	10830	15900	3'-6 1/2"	7'-8 3/4"	11'-11 3/4"
VFL-072-320	10830	15900	3'-6 1/2"	7'-8 3/4"	11'-11 3/4"
VFL-072-32P	10830	15900	3'-6 1/2"	7'-8 3/4"	11'-11 3/4"
VFL-072-42N	11860	17300	4'-3 3/4"	8'-4 3/4"	12'-7 3/4"
VFL-072-420	11860	17300	4'-3 3/4"	8'-4 3/4"	12'-7 3/4"
VFL-072-42P	11860	17300	4'-3 3/4"	8'-4 3/4"	12'-7 3/4"

NOTES:

1. ALL DIMENSIONS ARE IN FEET AND INCHES. WEIGHTS ARE IN POUNDS.
2. UNLESS OTHERWISE INDICATED, ALL CONNECTIONS 6 INCHES AND SMALLER ARE MPT AND CONNECTIONS 8 INCHES AND LARGR ARE BEVELED FOR WELDING AND GROOVED FOR VICTAULIC CONNECTION.
3. DIMENSIONS SHOWING LOCATION OF COIL CONNECTIONS ARE APPROXIMATE AND SHOULD NOT BE USED FOR PREFABRICATION OF CONNECTING PIPING.
4. FOR SUPPORT REQUIREMENTS, REFER TO THE SUGGESTED STEEL SUPPORT DRAWING.

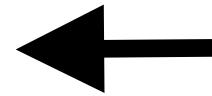

RENTALS - SALES - SERVICES

Portable
Air and Power



PortableAirandPower.com

888.365.5943